

HWS VERSION - 1750 RPM

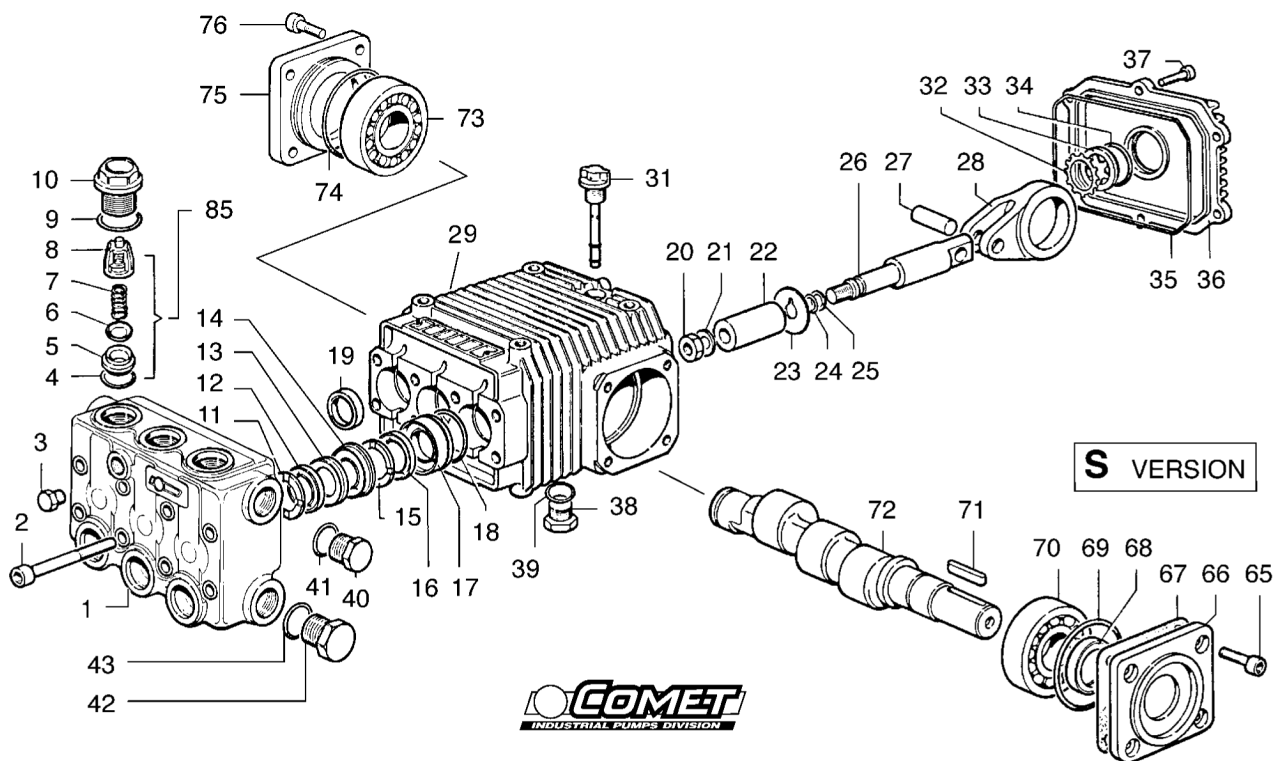

ITEM	PART No.	KIT	DESCRIPTION	Qty.	MODELS
1	3218.0122.00		MANIFOLD Ø 18 mm	1	
2	3609.0170.00		SCREW M8X80	8	
3	3202.0112.00		CAP G1/4	1	
4	1210.0046.00	A-D	O-RING 2,62X 17,13 mm	6	
5	3009.0087.00	A	VALVE SEAT	6	
6	3604.0017.00	A	VALVE PLATE	6	
7	1802.0177.00	A	SPRING	6	
8	1205.0025.00	A	VALVE CAGE	6	
9	1210.0048.00	A-D	O-RING 2,62X 20,24 mm	6	
10	3202.0230.00		CAP	6	
11	0009.0193.00	B	HEAD RING Ø18 mm	3	
12	1241.0022.00	B	PACKING V Ø18 mm	3	4040 S - 4540 S 5040 S
	1241.0035.00		PACKING Ø18 mm	3	4036 S - 4536 S
13	0009.0214.00	B	PACKING Ø18 mm	3	
14	0009.0216.00		INTERMED. RING Ø18 mm	3	
15	0009.0193.00	B	HEAD RING Ø18 mm	3	
16	1241.0022.00	B	PACKING V Ø18 mm	3	4040 S - 4540 S 5040 S
	1241.0035.00		PACKING Ø18 mm	3	4036 S - 4536 S
17	0009.0217.00		PACKING RETAINER Ø18 mm	3	
18	1210.0156.00	B-D	O-RING 1,78X31,47 mm	3	
19	0019.0066.00	D	OIL SEAL 20X30X5 mm	3	
20	0600.0054.00	C	NUT	3	
21	2811.0082.00	C	WASHER 8,2X17X1,5 mm	3	
22	0202.0022.00	C	PISTON Ø18 mm	3	
23	2812.0042.00	C	WASHER	3	
24	1210.0039.00	C-D	O-RING 1,78X 7,66 mm	3	
25	0009.0170.00	C-D	ANTI-EXTR. RING	3	
26	2409.0048.00		PISTON GUIDES	3	
27	3011.0016.00		WRIST. PIN Ø10X29 mm	3	
28	0205.0044.00		CON. ROD	3	
29	0403.0129.00		CRANKCASE	1	

ITEM	PART No.	KIT	DESCRIPTION	Qty.	MODELS
31	3200.0051.00		OIL DIPSTICK	1	
32	3019.0033.00		SNAP RING Ø18 mm	1	
33	3201.0012.00		OIL INDICATOR	1	
34	1210.0333.00	D	O-RING 1,78X23,52 mm	1	
35	1210.0216.00	D	O-RING 2,62X107,62 mm	1	
36	0402.0169.00		CRANCKCASE COVER	1	
37	3609.0030.00		SCREW M5X20	6	
38	3200.0007.00		CAP 3/8 GAS	1	
39	1210.0441.00	D	O-RING 2X14 mm	1	
40	3200.0007.00		CAP 3/8 GAS	1	
41	2811.0084.00		WASHER 16,7X22X1,5 mm	1	
42	3202.0015.00		CAP G1/2	1	
43	2811.0086.00		WASHER 21,2X27X1,5 mm	1	
65	3609.0058.00		SCREW M8X22	4	
66	0402.0170.00		FLANGE	1	
67	0601.0218.00		SHIM Ø62 0,05 mm	1	
	0601.0220.00		SHIM Ø62 0,10 mm	1	
	0601.0222.00		SHIM Ø62 0,19 mm	1	
	0601.0259.00		SHIM Ø62 0,25 mm	1	
68	0019.0007.00	D	OIL SEAL 25X52X7 mm	1	
69	1210.0388.00	D	O-RING	1	
70	0440.0012.00		ROLLER BEARING 25X62X18,25 mm	1	
71	1602.0013.00		KEY 8X7X30 mm	1	
72	0001.0324.00		CRANKSHAFT Ø24 mm	1	4036 S - 4040 S
	0001.0323.00		CRANKSHAFT Ø24 mm	1	5040 S
	0001.0346.00		CRANKSHAFT Ø24 mm	1	4536 S - 4540 S
73	0440.0012.00		ROLLER BEARING 25X62X18,25 mm	1	
74	1210.0388.00	D	O-RING	1	
75	0402.0171.00		FLANGE	1	
76	3609.0032.00		SCREW M6X20	4	
85	1220.0030.00		VALVE ASS. BLY.	6	